

CURTIS BELLOFRAM PUMP* FOR LONG-TERM USE IN EXTRACORPOREAL BLOOD CIRCUITS

WOLFGANG SEIDEL, M.D.,† NATHAN LEIPTZ,‡ FREDERICK BROWN,§ and
WILLEM J. KOLFF, M.D.
Department of Artificial Organs

IN recent models of pumps¹⁻⁵ used for extracorporeal blood circuits, the degree of damage to the blood has been reduced considerably. However, the hemolysis, as an indicator of this damage, may become severe when these pumps are used in long-term perfusions.⁶ Such long-term perfusions are expected to become useful in treating patients who at present have hopeless, acute coronary infarction and other forms of myocardial failure. This report describes a new pump that embodies the principle of rolling diaphragms; it combines the advantages of a reciprocating pump with the satisfactory blood-handling properties of a membrane type of device.

Description of the Pump

The design is basically that of a piston type of pump (*Fig. 1* and *Table 1*). A Bellofram rolling diaphragm|| made of Silastic with a dacron mesh reinforcement serves as the seal between the piston and the considerably larger cylinder. The valves (V) are tricuspid semilunar, or flat rubber, or ball valves. The diaphragm is tightly fixed between a retaining plate (R) and the piston body (P). The piston rod (P₁), which has a central thread, forms the nut to fix to the retaining plate. The diaphragm runs down the piston skirt, forms a 180-degree convolution, and covers the whole cylinder wall of the blood chamber. It is held in place by the bead (G) that fits into a corresponding groove in a flange on the cylinder (C). When the bead is compressed between the flange of the cylinder and the top part (T) by means of a large tightening screw (Sc), a seal is formed. The dome topping the blood chamber, of which a small part (T) is seen, is slightly excavated to permit easy removal of residual air during priming. There are two openings (T₁) for the blood inlet and outlet. These carry special rims that serve as seats for the valves.

This work was supported by Grant No. H-4448 to Doctor Kolff from the National Institutes of Health, Bethesda, Maryland.

**Donated by the William Abrams Foundation; built by Curtis Industries, Inc., Euclid, Ohio, under the direction of Mr. Howard Abrams.*

†Formerly Fellow in the Department of Artificial Organs; present address: Marburg/Lahn von Harnackstrasse 22, Germany.

‡Assistant Manager, Curtis Industries, Inc., Euclid, Ohio.

§Technician in the Department of Artificial Organs.

||Manufactured by Bellofram Corporation, Burlington, Massachusetts.

CURTIS BELLOFRAM PUMP

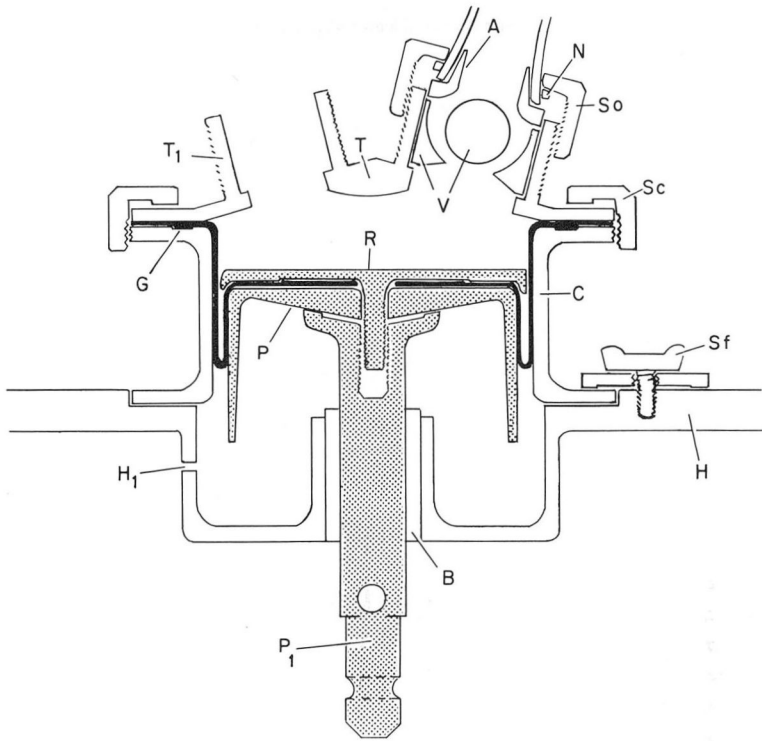

Fig. 1. Diagrammatic scheme of the pump housing and piston assembly.

Table 1.—Specifications of the rolling diaphragm blood pump

Motor housing: height from floor to pump unit	40 cm.
Surface area	43 cm. by 60 cm.
Cylinder bore	7.5 cm.
Piston diameter	6.5 cm.
Outlet, inner diameter	19 mm.
Inlet, inner diameter	25 mm.
Stroke: length	0 to 25 mm.
volume	0 to 96 ml.
rate	0 to 300 rpm

Each valve is locked in place by a ring nut (So), which also serves to attach the plastic tubing leading to the pump. The plastic tubing is held tightly between a small nylon ring (N) and a tapered connecting piece (A). The nylon ring prevents torsion of the tubing during tightening of the ring nut. Moreover, the ring nut

forces the connecting piece against the valve (V). Washers, not shown, between the ring nut and the valve, and between the valve and the top, help to seal these connections.

The pump assembly is made of stainless steel; the parts in contact with blood are highly polished. The unit is assembled and then is sterilized with ethylene oxide. Specifications of the pump are given in *Table 1*. After being sterilized, two of these pump units are placed in corresponding seats on top of the motor housing (*Fig. 2*), and are held in place by locking screws (Sc) (*Fig. 1*). The piston rod is

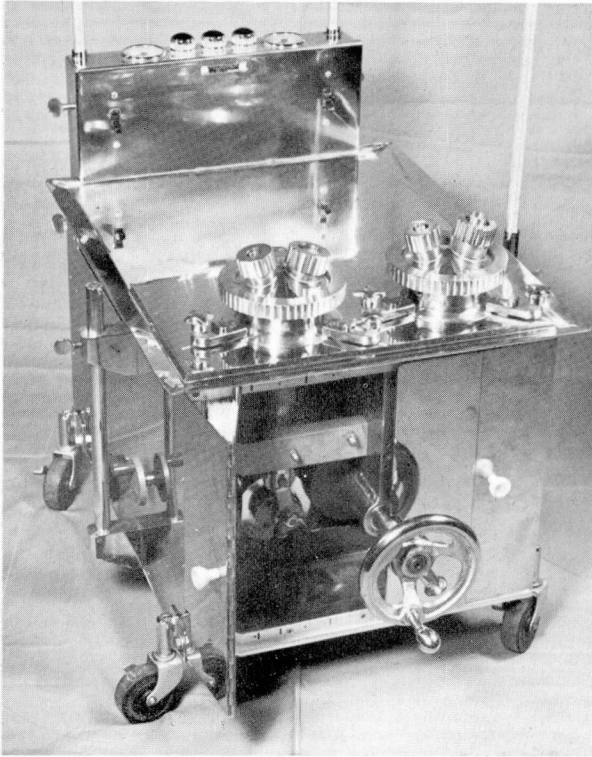

Fig. 2. Machine with the pumping units assembled.

easily guided into its bearing (B) and is locked to the crankshaft by means of a ball lock.

Two 1/3-hp. explosion-proof electromotors are mounted inside the motor housing. Zero-Max gear boxes* allow a stepless change of the output shaft speed from 0 to 300 rpm. A crank with adjustable eccentric performs the force transmission to the pistons, and permits changes in stroke length from 0 to 25 mm. The transmission mechanism is easily accessible by sliding doors in front of the housing.

*Manufactured by Revco, Inc., Minneapolis, Minnesota.

The frequency of each of the two separate pumping units is regulated separately, but can be synchronized by means of a central gear for alternate or synchronous action. A tachometer, calibrated for several stroke volumes, is connected to the output shaft of the Zero-Max transmission, and provides direct reading of the pump output per minute. When in synchronized operation, both pumps can be operated by only one electromotor or, in case of power failure, by a hand wheel that is provided for manual operation.

The chrome-plated housing is designed for convenience in cleaning. The motors are protected against contamination by spilled fluids. Special excavations prevent the access of spilled blood into the housing at any time during disassembly of the pumping unit. Power indicator lights, spare electric outlets, rods for attachment of a membrane oxygenator⁷ and other parts of the extracorporeal circulation, and a drawer for spare parts and tools complete the unit. Cleaning, assembling, sterilizing, and operation of the unit are made as easy as possible. The diaphragms are inexpensive and disposable.

Testing and Results

The pump was tested for endurance in continuous operation for longer than one week at flow rates of from 3 to 5 liters against a resistance of about 300 mm. of Hg. It has been used for more than 20 animal experiments.

Studies of hemolysis were undertaken according to the procedures described previously.¹ A correlation was found between the degree of hemolysis and the type and quality of the valves used (*Table 2*). Whereas stiff polyurethane valves,

Table 2.—*The influence of valve types on the degree of hemolysis with the Curtis Bellofram pump*

Type of valve	Hemolysis range, mg. per 100 ml. of free plasma hemoglobin per 30 min. of pumping
Stiff polyurethane (three cusps)	16-18
Soft, thin polyurethane (three cusps)	4-8
Flap, flat rubber	3-5
Silastic ball with metal cage	4-10

selected for endurance, caused damage to the blood, the simple flap valves caused as little hemolysis as 0.033 mg. of free hemoglobin per liter of blood per minute.¹ With proper valves, the hemolysis caused by this pump was as low as that of any pump we have tested.¹

Discussion

The hemolysis caused by roller pumps and finger pumps is believed to be created by the rubbing and touching of the ventricular walls against each other. The hemolysis has been reduced by so-called "nonocclusive" pumps, but then the turbulence of the regurgitating blood may become the major source of damage. It was believed that the prevention of rubbing or touching of the chamber walls would greatly reduce the amount of hemolysis, as this had been shown by Cahill and Kolff² to occur with the Dale-Schuster pump at low flow rates. In the present study it became apparent that the hemolysis is closely related to and dependent on the amount of destruction caused by some valves.

The Bellofram rolling diaphragm seal prevents the piston from touching the cylinder. This makes the application of a reciprocating pump in an extracorporeal circuit possible. One advantage of the reciprocating pumps is the direct proportion between stroke length and stroke volume. Therefore, a tachometer attached to the output shaft of the transmission presents direct readings of the pump output per minute when calibrated for the stroke length to be used.

The pump housing is low to allow gravity drainage from the vena cava of a patient or from an oxygenator into the pump units. This solves the problem of the necessity of positive pressure: the convolution of a rolling diaphragm would be inverted if more than minimal suction forces occur during diastole. For the same reason, the connection from the venous reservoir or the oxygenator should be wide and as short as possible, and the inlet valve may not impede the filling of the pump chambers. With the help of the attached rods, the low pump housing with the two motors forms a stable, small stand to which the rest of the extracorporeal circuitry can be affixed. The pulsatile flow of the Curtis Bellofram pump aids in the even distribution of blood through our membrane oxygenator.⁷ During a recent clinical application there was no visible hemolysis after nine and three-quarter hours of use of a membrane oxygenator with this pump for partial bypass in a patient with intractable heart failure.

Summary

1. A reciprocating blood pump for extracorporeal blood circuits is described, which uses disposable rolling diaphragms for the seal between piston and cylinder. Two complete pump units are provided, which can be operated separately or in synchronization.
2. The stroke volume of the pump is adjustable from 0 to 96 ml.; the stroke rate ranges from 0 to 300 strokes per minute.
3. A tachometer provides direct reading of the output of blood per minute.
4. Studies of hemolysis indicated that the blood pump causes comparatively little damage to the blood. Damage if any is related to the kinds of valves employed.

5. The pulsating flow is of advantage in obtaining even distribution of blood through certain membrane oxygenators.

References

1. Brown, F.; Seidel, W., and Kolff, W. J.: Hemodialysis caused by pumps at flow rates of 2 liters. *Tr. Am. Soc. Artificial Int. Organs* 7: 350-354, 1961.
2. Cahill, J. J., and Kolff, W. J.: Hemolysis caused by pumps in extracorporeal circulation (in vitro evaluation of pumps). *J. Appl. Physiol.* 14: 1039-1044, 1959.
3. Kolff, W. J.: Artificial organs; heart; as used for heart operations, p. 33-36, *in* Glasser, O., editor: *Medical Physics*, vol. 3. Chicago: The Year Book Publishers, Inc., 1960, 754 p.
4. Neptune, W. B.; Bougas, J. A., and Panico, F. G.: Open-heart surgery without the need for donor-blood priming in the pump oxygenator. *New England J. Med.* 263: 111-115, 1960.
5. Head, L. R., and associates: Operation of roller pump for extracorporeal circulation. *J. Thoracic & Cardiovas. Surg.* 39: 210-220, 1960.
6. Salisbury, P. F., and associates: Physiological factors in use of pump-oxygenator. *Tr. Am. Soc. Artificial Int. Organs* 1: 68-71, 1955.
7. Kylstra, J. A.; Mouloupoulos, S. D., and Kolff, W. J.: Further development of ultra-thin Teflon membrane gas exchanger. *Tr. Am. Soc. Artificial Int. Organs* 7: 355-360, 1961.