

Macromolecular solute kinetics in on-line membrane plasma treatment systems¹

Paul S. Malchesky, D. Eng.
Jeffery J. Starre
Jan Wojcicki, Ph.D.
Andrzej Werynski, Ph.D.
James W. Smith, M.D., Ph.D.
Yasuhisa Abe, M.D.
Yukihiko Nosé, M.D., Ph.D.

Macromolecule removal by membrane plasma separation with on-line plasma filtration in rheumatoid arthritis patients undergoing cryofiltration treatments has been quantified. A single pool model provided good estimates of post-treatment concentrations of immunoglobulins, albumin, total globulin, and total cholesterol. Net generation of these solutes as well as rheumatoid factor and circulating immune complexes has been shown to be highly individual and related to intertreatment durations and concomitant drug therapy.

Index terms: Arthritis, rheumatoid • Immunoglobulins • Plasmapheresis

Cleve Clin Q 51: 127-133, Spring 1984

Plasma exchange has been used in the treatment of a variety of disease states.¹ Membrane plasma separation is particularly preferred when the plasma is to be treated on-line,² since the plasma product that is produced contains no or minimal blood cellular elements. Sieving of macromolecular weight solutes by available membrane plasma separators is generally greater than 90%. The use of secondary membrane filters on-line with or without active cooling (cryofiltration)^{3,4} to remove macromolecular weight solutes has been shown to be of clinical benefit without requiring the infusion of plasma products.⁵⁻⁷ Sieving of macromolecular weight solutes through this secondary filter may be highly variable depending upon the state of the disease, treatment schedules, and other treatment and clinical parameters in addition to differences in the membrane and module design and the operating conditions.

¹ Department of Artificial Organs, The Cleveland Clinic Foundation (P.S.M., J.J.S., J.W., J.W.S., Y.A., Y.N.) and the Institute of Biocybernetics and Biomedical Engineering, Warsaw, Poland (A.W.). Submitted for publication Aug 1983; revision accepted Sept 1983.

This paper was presented in part at the International Symposium on Kinetic Modeling in Artificial Organs in Rostock-Warnemünde, GDR, Sept 28-30, 1982.

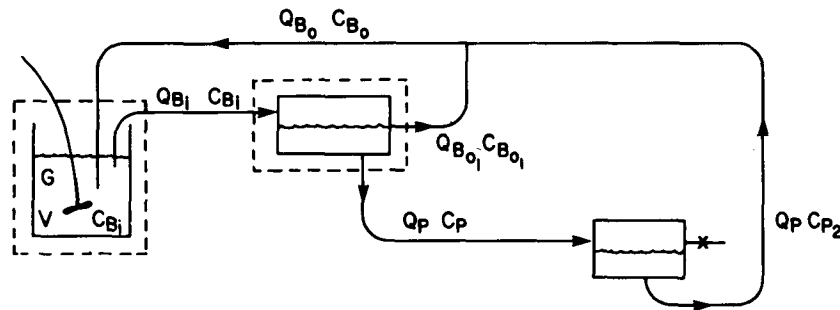

Fig. 1. Schematic of double membrane circuit for on-line plasma treatment.

Quantitation of the removal process of macromolecules is important to the clinical therapy. Prebiochemical to postbiochemical changes provide only limited information on the treatment process and do not allow prescription of the treatment. It is the objective of this study to quantitate the removal process and assess generation and compartment volumes of the solutes of interest in a double membrane plasma treatment system. The information gained from the results of such studies will provide guidelines for the selection of treatment parameters such as blood and plasma flow rates, time of treatment, filter selection, and treatment frequency requirements.

Single-pool kinetics—mathematical development*

The circuit employed is schematically represented in *Figure 1*. It is assumed that the solutes reside in a single body pool (*V*) that is fully mixed. Although the concept of a single pool may be a somewhat simplistic assumption, single-pool models have been applied for plasma exchange alone with centrifugal⁸ or membrane⁹ systems with reasonable success. With the net generation (*G*) of the solute, equilibrium is assumed to occur within the body pool. The sieving coefficient (*SC*) of the plasma separator, the first filter, is defined as $SC_1 = C_P/C_{Bi}$ and is not necessarily unity, but no mass deposition of the solute of interest is assumed to occur on this filter. The sieving coefficient of the second filter is defined as $SC_2 = C_{P2}/C_P$ and is typically less than unity with mass deposition of the solute of interest in this filter. The volumes of infusion solution administered are not significant and the plasma volume is taken to be constant. Correction for dilution or hemoconcentration of the solute is, however, ac-

counted for. Extratreatment removal (*K*), e.g., that due to the reticuloendothelial system, is included in the model formulation.

From a mass balance on the system:

$$\Delta mass = Q_{Bi}C_{Bi} - Q_{Bo}C_{Bo} \quad [1]$$

$$\Delta mass = Q_{Bi}C_{Bi} - Q_{Bo1}C_{Bo1} - Q_P C_{P2} \quad [2]$$

where $Q_{Bo1} = Q_{Bi} - Q_P$ [3]

From a mass balance around the first filter (plasma separator)

$$C_{Bo1} = [Q_{Bi}C_{Bi} - Q_P C_{Bi}(SC_1)] / (Q_{Bi} - Q_P) \quad [4]$$

Using equations [2], [3], and [4] and the definition of the sieving coefficient for the second filter (cryofilter)

$$\Delta mass = Q_P C_{Bi}(SC_1)[1 - (SC_2)] = d(V C_{Bi}) / dt \quad [5]$$

For constant volume

$$V dC_{Bi} / dt = -Q_P C_{Bi}(SC_1)(1 - (SC_2)) + G - K C_{Bi} \quad [6]$$

Following integration

$$C_{B_f} = \left[C_{B_s} \exp - \frac{G}{Q_P(SC_1)(1 - (SC_2)) + K} \right] \times \exp - \left[\frac{Q_P(SC_1)(1 - (SC_2)) + K}{V} \right] t + \frac{G}{Q_P(SC_1)(1 - (SC_2)) + K} \quad [7]$$

where C_{B_f} is the expected blood concentration at time *t*. For short treatment times, the extratreatment removal (*K*) may be considered negligible; likewise, the influence of the net generation *G*, during the treatment period, can be shown to be small and may also be neglected.

Therefore,

$$C_{B_f} = C_{B_s} \exp - (Q_P t / V)(SC_1)(1 - (SC_2)) \quad [8]$$

* The appendix contains a listing and description of nomenclature and subscripts used in this mathematical development.

Table 1. Patient population

Patient	Sex	Age	RA Class	Type of filters	Equipment
1	F	64	IV	Asahi	Cryomax
2	F	50	III	Asahi	Cryomax
3	F	57	III	Kuraray	EPS
4	F	48	III	Kuraray	EPS
5	M	65	III	Asahi	Cryomax
6	M	42	III	Kuraray	EPS
7	F	41	III	Kuraray	EPS
8	F	59	III	Asahi	Cryomax
9	F	55	III	Asahi	Cryomax
10	M	27	III	Kuraray	EPS
11	F	50	III	Kuraray	EPS
12	F	36	II	Kuraray	EPS
13	F	59	III	Asahi	Cryomax

EPS = Extracorporeal Plasma System.

The net generation rate G , which is measured between treatments, is defined as the generation rate minus catabolic rate. It is the net appearance rate for the solute and is calculated as

$$G = (C_{pre} - C_{post})V/t_{id} \quad [9]$$

where C_{pre} and C_{post} are blood solute concentrations between time, t_{id} , of treatments.

Patient population and data analysis

Thirteen adult patients with active seropositive rheumatoid arthritis (RA) undergoing cryofiltration treatment were evaluated. As shown in *Table 1*, ages ranged from 27 to 65 years (average, 50.2 years). Ten patients were female. All patients had previously failed at least one major drug therapy such as gold, chelating agent, or cytotoxic agent, and a maximal trial of nonsteroidal anti-inflammatory medication. Six patients were treated by the Cryomax (Parker Biomedical, Irvine, CA), with the Plasmaflo Hi-05 plasma separator and Plasmaflo cryofilter (Asahi Medical Co, Tokyo, Japan). The Extracorporeal Plasma System (Ex-

tracorporeal Medical Specialties, Inc, King of Prussia, PA) using the PVA-SA plasma separator and PVA-MN cryofilter (Kuraray Inc., Osaka, Japan) was used in 7 patients. *Table 2* outlines the properties of these hollow fiber modules. The circuitry employed was essentially as described in previous publications.³⁻⁵

The gamma globulins IgG, IgA, and IgM, circulating immune complexes (CIC), and rheumatoid factor (RF) were chosen for the analysis because of their changes in RA patients undergoing treatment. Immunoglobulins were assayed by nephelometry (Hyland Diagnostics, Div. of Trav-enol Laboratories, Inc, Deerfield, IL) or radial immunodiffusion (Miles Laboratories, Inc, Elkhart, IN), CIC by Clq-binding assay described by Zubler et al¹⁰ and RF by nephelometry according to the method of Jones et al.¹¹ Albumin (Alb) was assayed by the bromocresol green method,¹² and total protein by the method of Skeggs and Hochstrasser.¹³ Total globulin was calculated as total protein minus albumin. Total cholesterol (T chol) was assayed by the enzymatic method of Leon and Stasiw.¹⁴ Albumin, total protein and total cholesterol assays were performed by the automated procedures of Technicon (Technicon Instruments Corp, Tarrytown, NY). Assays of samples taken before extracorporeal circulation (*pre*) and after solution reinfusion (*post*) as well as from samples taken from the inlets to the modules and from the filtrate sides during the treatment were made to determine the sieving properties of the modules. Typically, sieving was determined at about one hour of perfusion.

To correct for dilution or concentration of these solutes due to the extracorporeal treatment, correction of the solute concentration was made based upon concentration changes in red blood cell count (*RBC*) and total hemoglobin (*Hgb*) as directly analyzed by the Coulter Counter (Coulter Electronics, Inc, Hialeah, Florida). The

Table 2. Hollow fiber modules

		Name	Membrane	No. fibers	ID	Fiber length	Area
Asahi	Plasma separator	Hi-05	Cellulose acetate	3420	330 μ m	22 cm	0.60 m ²
	Cryofilter	Plasmaflo	Cellulose acetate	3500-3900	370 μ m	24.5 cm	0.65 m ²
Kuraray	Plasma separator	SA	Polyvinyl alcohol	2100	330 μ m	34 cm	0.63 m ²
	Cryofilter	MN	Polyvinyl alcohol	2400	400 μ m	20 cm	0.44 m ²

ID = internal diameter.

dilution factor is calculated as:

$$dilution\ factor = 0.5 \left[1 - \frac{Postsample\ Hgb}{Presample\ Hgb} \right] + 0.5 \left[1 - \frac{Postsample\ Hgb}{Presample\ Hgb} \right] \quad [10]$$

and the corrected solute concentration, $C_{B_{sc}}$, is calculated as

$$C_{B_{sc}} = Preconcentration (1 - dilution\ factor) \quad [11]$$

$C_{B_{sc}}$ is the expected concentration assuming that only dilution or hemoconcentration occurred and that there were no other losses or gains. The rationale of making the dilution correction on the preconcentration as opposed to the postconcentration is that the presample is taken directly from the patient and is not affected by the extracorporeal circulation.

Solute pool volume was taken to be the patient's plasma pool volume. Plasma pool volume, V , was calculated as:

$$V = blood\ volume (1 - red\ cell\ fraction) \quad [12]$$

The red cell fraction is the hematocrit directly calculated from the RBC and the mean corpuscular volume of the red cell determined by the Coulter counter. Blood volume was calculated from equations relating sex and weight to blood volume.¹⁵

For men

$$Blood\ volume = 1530 + 41.0\ W \quad [13]$$

Table 3. Percent difference of calculated postconcentration to actual solute concentration

	No. patients	n	Mean ± SD	% Data within model limits*
IgG	6	9	-2.14 ± 15.87	78
IgA	8	10	-13.39 ± 11.42	70
IgM	5	6	-5.07 ± 26.22	50
Alb	7	10	3.30 ± 9.16	100
T glb	5	7	3.71 ± 9.38	100
T chol	9	14	0.84 ± 9.24	93
RF	1	1	-0.23	100
				84 overall

* Multiple parameter variances for mean values of $\frac{Q_{pl}}{V}$, SC'_1 and SC_2 of 1.35, 0.90, and 0.85. Alb = albumin, T glb = total globulin, T chol = total cholesterol, RF = rheumatoid factor.

Table 4. Chemical assay variances

Chemical assay	% Coefficient of variance
IgG	3.13
IgA	3.75
IgM	3.95
Albumin	2.4
Total globulin	3.9
Total cholesterol	1.5
Clq-binding immune complexes	<5.0
Rheumatoid factor	3.5

For women

$$Blood\ volume = 864 + 47.2\ W \quad [14]$$

where W is the patient weight in kg and blood volume is in milliliters.

In actual clinical practice the sieving of solutes in the first filter, the plasma separator, may not be 100% and the outlet concentration may be different from the inlet concentration. To minimize errors in the value of the sieving coefficient for the first filter, the mean concentration of the solute on the blood side was used.

$$SC' = \frac{2C_P}{C_{Bi} + C_{Bo_1}} \quad [15]$$

where C_{Bo_1} is defined in equation 4.

Comparison of the actual postsolute concentration with that estimated (% difference) from equation 8 was made.

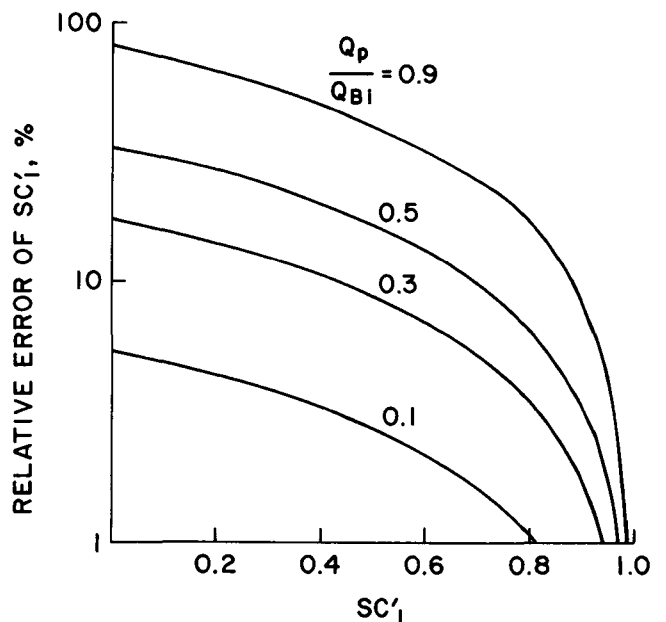

Fig. 2. Relative error of SC'_1 vs SC_1 for varying Q_P/Q_{Bi} .

$$\% \text{ difference} = \frac{[\text{actual post}] - [\text{calculated post}]}{[\text{actual post}]} \quad [16]$$

Extratreatment removal was calculated by setting $G = 0$ in equation 7 and C_{Bf} equal to the actual postconcentration.

Results and discussion

For 220 treatments analyzed in 13 patients, 57% difference calculations were made. The calculated postvalues in comparison to the actual postconcentrations were reasonably close, as illustrated in *Table 3*. However, the standard deviations were relatively large. The high standard

deviations observed in *Table 3* for the percentage differences in estimating the postsolute concentrations may in part be related to errors in determining the various input parameters to the model. For each sieving coefficient a variance was assessed based on the chemical assay variances (*Table 4*) and the estimated errors involved with the individual parameter determinations. The variance assigned SC_1 is 10% and SC_2 is 15%. The variance of V is ± 25 .¹⁵ To evaluate the difference in results in using SC'_1 for SC_1 , the relative error versus SC'_1 was evaluated for varying Q_{pt}/Q_{Bi} as shown in *Figure 2*. For all of the treatment data analyzed, the relative error was less than 4%, with the majority less than 2%.

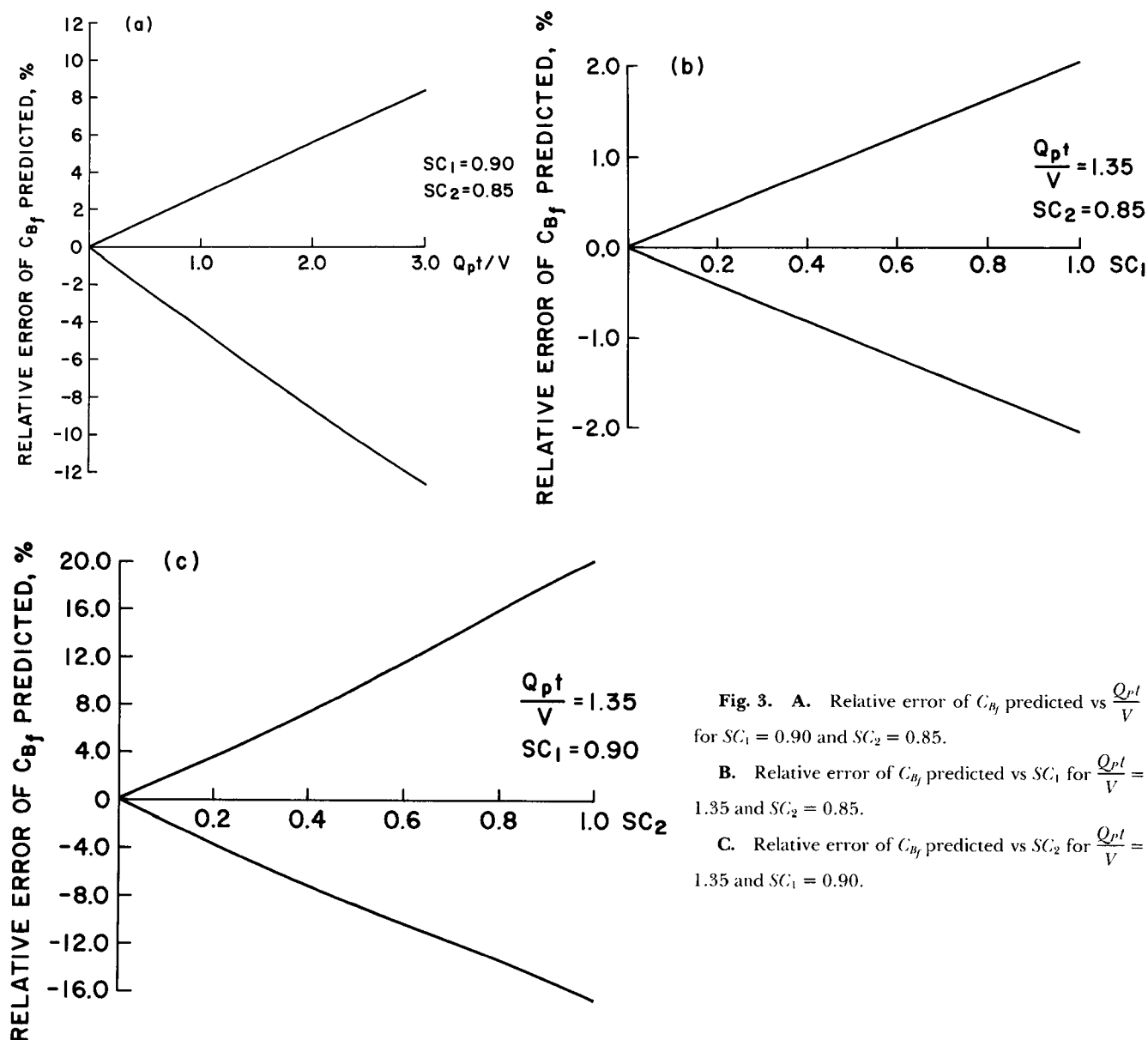

Fig. 3. A. Relative error of C_{Bf} predicted vs $\frac{Q_{pt}}{V}$ for $SC_1 = 0.90$ and $SC_2 = 0.85$.

B. Relative error of C_{Bf} predicted vs SC_1 for $\frac{Q_{pt}}{V} = 1.35$ and $SC_2 = 0.85$.

C. Relative error of C_{Bf} predicted vs SC_2 for $\frac{Q_{pt}}{V} = 1.35$ and $SC_1 = 0.90$.

Table 5. Estimated extratreatment removal (ml/min)

Solute	n	Mean \pm S.D.	Maximum
IgG	5	0.97 \pm 0.89	2.08
IgA	8	2.38 \pm 1.74	5.94
IgM	3	4.69 \pm 4.06	8.69
Alb	3	1.13 \pm 0.90	2.09
T glb	1	1.74	...
T chol	6	0.92 \pm 0.98	2.78
RF	1	0.16	...

See Table 3 for abbreviations.

With only single parameter variances, C_{BF} may be predicted to within the limits shown in Figure 3 for the given variations of Q_{pl}/V , SC_1 and SC_2 . From mean values of the patient studies of $Q_{pl}/V = 1.35$, $SC_1 = 0.90$ and $SC_2 = 0.85$, 84% of the results were within the maximum limits of error, validating the high accuracy of the model.

Of particular sensitivity in the model is the value of SC_2 . In double-membrane plasma filtration, this is of particular concern since sieving is not a constant, but varies with time. Additional data on the variation of sieving with pressure, time, flow, and pathologic state should be helpful in reducing the standard deviation for this parameter. Further, the value of V shows a high standard deviation. Radioisotope markers or alternative methods of estimating blood volumes in patients with RA should improve the accuracy of this determination. Even though some solutes analyzed (e.g., albumin) are rapidly transported between intravascular and extravascular pools, the single pool model is an adequate representation of the treatment. In cases in which the cal-

culated postconcentration was greater than actual postconcentration, the extratreatment clearance, K , was calculated. The estimated mean extratreatment removal, such as by the reticulo-endothelial system, and the maximum values of solute clearance are shown in Table 5. With further studies of increased sensitivity, K could be established as a function of the patient, solute, concentration of solute, and time of treatment.

Net generation rates were assessed for inter-treatment intervals of greater than one day. Table 6 outlines overall means and means of specific intertreatment time periods for all solutes. Mean net generation rates varied as a function of the patient studied, interval between treatments, and concomitant drug therapy. As the time interval between treatments was extended from one to four days during the initiation of therapy to greater than one week in maintenance therapy, net generation was seen to decline as shown in Table 6. In comparing net generation rates for intertreatment intervals of one to four days to that of one to three weeks with the paired t -test, P was 0.007 for IgG, 0.004 for IgA, 0.03 for IgM, 0.0005 for Alb, 0.02 for T glb, 0.04 for T chol, 0.34 for Clq, and 0.01 for RF. This same tendency of decreasing net generation rate with extended intertreatment intervals is exhibited for intertreatment periods of one to four days in comparison to intervals of greater than three weeks. Noteworthy is the high variability and standard deviation of immune complexes with intertreatment time intervals. As shown by the results, continued cryofiltration is associated with

Table 6. Overall mean net generation rates (U/kg/day) of macromolecular solutes with varying intertreatment time intervals

Inter-treatment time, days		IgG (mg)	IgA (mg)	IgM (mg)	Alb (g)	T glb (g)	T chol (mg)	Clq (units)	RF (RLS)
1 \leq t < 4	Generation rate	18.65 \pm 15.38	6.60 \pm 6.33	6.31 \pm 6.27	0.084 \pm 0.041	0.068 \pm 0.034	5.01 \pm 2.84	897.6 \pm 2110.9	384.8 \pm 367.1
	No. of data	63	63	64	66	66	66	68	63
4 \leq t < 7	Generation rate	11.99 \pm 11.26	1.45 \pm 5.86	4.82 \pm 10.96	0.046 \pm 0.015	0.040 \pm 0.013	3.01 \pm 1.63	132.2 \pm 1089.5	132.7 \pm 212.9
	No. of data	23	23	23	27	27	27	33	32
7 \leq t < 21	Generation rate	3.24 \pm 7.85	1.35 \pm 1.65	2.78 \pm 2.82	0.021 \pm 0.011	0.020 \pm 0.013	1.42 \pm 0.85	357.1 \pm 707.8	110.9 \pm 109.7
	No. of data	25	24	23	36	36	36	31	31
t \geq 21	Generation rate	4.38 \pm 2.95	1.05 \pm 1.05	1.94 \pm 1.62	0.012 \pm 0.003	0.010 \pm 0.006	0.68 \pm 0.35	857 \pm 1205	58.1 \pm 48.0
	No. of data	16	16	16	13	13	13	16	10
Overall		12.67 \pm 14.03 127	4.09 \pm 5.87 126	4.86 \pm 6.78 126	0.054 \pm 0.042 142	0.045 \pm 0.034 142	3.35 \pm 2.27 142	609 \pm 1628 148	251.0 \pm 344.6 136

RLS = relative light scattering units.
See Table 3 for other abbreviations.

Table 7. Generation rates with (+) and without (-) methotrexate

Patient	Methotrexate	IgG mg/kg-day	IgA mg/kg-day	IgM mg/kg-day	Clq binding U/kg-day
1	-	35.36 ± 13.98	22.59 ± 4.54	12.08 ± 2.72	7865 ± 382
	+	7.69 ± 2.54	4.00 ± 1.22	2.28 ± 0.88	898 ± 1749
13	-	14.09 ± 2.22	1.93 ± 0.04	5.64 ± 1.80	153 ± 393
	+	12.51 ± 11.37	2.74 ± 3.84	1.89 ± 1.28	168 ± 158

a decrease in immunoglobulin net generation. Depending upon the immunoglobulin that may be critically related to the disease state, such generation information may be useful in the scheduling of treatments. It is important to note, however, that short treatment intervals in all cases preceded the long intervals. The variation of generation with drug therapy was examined in selected cases. *Table 7* outlines the generation rate data for patients treated with methotrexate. Methotrexate inhibits the reduction of folic acid to tetrahydrofolic acid reductase. By interfering with cell reproduction it may have an immunosuppressive effect. Patient 1 showed a dramatic response with decreased immunoglobulin generation to this drug. In patient 13, the effects are not as evident with a significant decrease for IgM only. Response to a drug varies with the individual. Further increases in sample size should help to clarify these differences.

References

- Gurland HJ, Samtleben W, Blumenstein M, Randerson DH, Schmidt B. Clinical applications of macromolecular separations. *Trans Am Soc Artif Intern Organs* 1981; **27**:356-363.
- Malchesky PS, Asanuma Y, Smith JW, et al. Macromolecule removal from blood. *Trans Am Soc Artif Intern Organs* 1981; **27**:439-444.
- Malchesky PS, Asanuma Y, Zawicki I, et al. On-line separation of macromolecules by membrane filtration with cryogelation. [In] Sieberth HG, ed. *Plasma Exchange*. Stuttgart, Schattauer Verlag, 1980, pp 133-139.
- Nosé Y, Malchesky PS, Smith, JW. Hybrid artificial organs: are they really necessary? *Artif Organs* 1980; **4**:285-290.
- Smith JW, Kayashima K, Asanuma Y, et al. Membrane plasma separation with on-line plasma cryofiltration for treatment of autoimmune disease. *Artif Organs* 1981; **5**(suppl): 129-134.
- Krakauer RS, Asanuma Y, Zawicki I, Calabrese L, Malchesky P, Nose Y. Circulating immune complexes in rheumatoid arthritis: selective removal by cryogelation with membrane filtration. *Arch Intern Med* 1982; **142**:395-397.
- Malchesky PS, Smith JW, Kayashima K, Asanuma Y, Nosé Y. Membrane plasmapheresis with cryofiltration in rheumatoid arthritis. *Cleve Clin Q* 1983; **50**:11-18.
- Calabrese LH, Clough JD, Krakauer RS, Hoeltge GA. Plasmapheresis therapy of immunologic disease. Report of nine cases and review of the literature. *Cleve Clin Q* 1980; **47**:53-72.

- Randerson DH, Blumenstein M, Habersetzer R, Samtleben W, Schmidt B, Gurland HJ. Mass transfer in membrane plasma exchange. *Artif Organs* 1982; **6**:43-49.
- Zubler RH, Lange G, Lambert PH, Miescher PA. Detection of immune complexes in unheated sera by a modified ¹²⁵I-C1q binding test. Effect of heating on the binding of C1q by immune complexes and application of the test to systemic lupus erythematosus. *J Immunol* 1976; **116**:232-235.
- Jones CE, Rousseau RJ, Maxwell KW. Quantitation of rheumatoid factor activity by nephelometry. *Am J Clin Pathol* 1979; **72**:432-436.
- Doumas BT, Watson WA, Biggs HG. Albumin standards and the measurement of serum albumin with bromocresol green. *Clin Chim Acta* 1971; **31**:87-96.
- Skeggs LT Jr, Hochstrasser H. Multiple automatic sequential analysis. *Clin Chem* 1964; **10**:918-936.
- Leon LP, Stasiw RO. Performance on automated enzymatic cholesterol on SMATM12/60 and AutoAnalyzer-IITM instruments (abst). *Clin Chem* 1976; **22**:1220.
- Wintrobe MM et al, ed. *Clinical Hematology*. 8th ed. Philadelphia, Lea & Febiger, 1981, p. 1886.

Appendix

- C = concentration of solute, unit/ml
 G = solute net generation rate (generation rate - catabolic rate), unit/min
 K = extratreatment removal, ml/min
 Q = flow rate, ml/min
 SC = sieving coefficient
 t = time of treatment, min
 t_{id} = intertreatment time, min
 V = patient plasma volume, ml
 W = patient weight, kg

Subscripts

- B = blood
 c = corrected
 f = final
 i = inlet
 o = outlet
 P = plasma
 s = initial
 1 = first filter
 2 = second filter